

Senior Flexonics Pathway is the world leader in the design and fabrication of expansion joints for the Catofin® process. SF Pathway has:

- The largest installed base of Catofin® style expansion joints in the world
- 1200+ Units Operating today in more than 15 Plants
- More Catofin® service Operational Hours than all other manufacturers combined

Expansion joints are a critical part of the system and without them the plant could not operate. Catofin plants can have more than 100 expansion joints. The service is severe with very high temperatures, extreme flow velocities, and large cyclic movements.

Catofin expansion joints require special consideration for design, installation, and maintenance. The design must address pressure capacity, thermal stress, potential coke formation, flow induced vibration, and weight support. For security, the bellows must have redundancy and advance warning capability. **Correct installation and subsequent monitoring is imperative for long life expectancy.**

Because there is such a large number of expansion joints in each plant, design and manufacturing must be executed with the upmost attention to detail. There is very little margin for error. Users must make sure that the licensor's specification is being followed and that important features are present on the expansion joint. This will insure that the expansion joints will have a long life.

Pathway has more experience with this process than any other expansion joint company. We have worked very closely with the licensor for many years to develop the designs and implement improvements to prolong the life of the expansion joints in this very severe service.

That considerable experience is the reason that most Catofin and MTBE plants continue to place their trust in Senior Flexonics Pathway with expansion joint design and fabrication in this service.

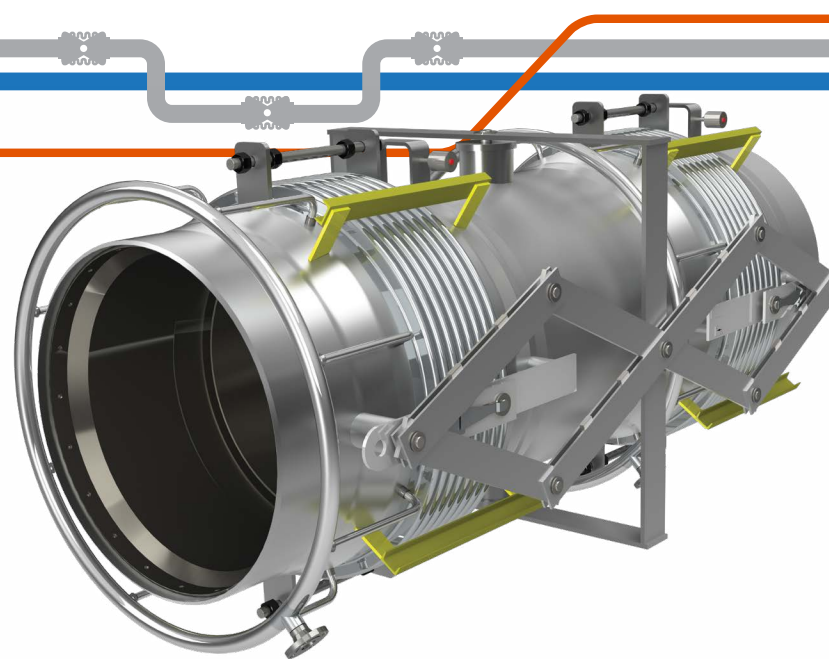

FEATURES OF CATOFIN EXPANSION JOINTS

- 2-Ply testable bellows
- 321H Bellows (annealed after forming)
- 321H Pipe and liners
- Purge system for hydrocarbon expansion joints
- Internal insulation to keep the bellows operating temperature below the creep range
- External covers to protect bellows against weather
- Slotted hinges for weight support
- Movement indicators
- Shipping bars secure length during shipping

The two most common types of expansion joints in Catofin service are in the inlet and outlet headers. Shown here is a hydrocarbon feed expansion joint with integral purge piping and distribution header.

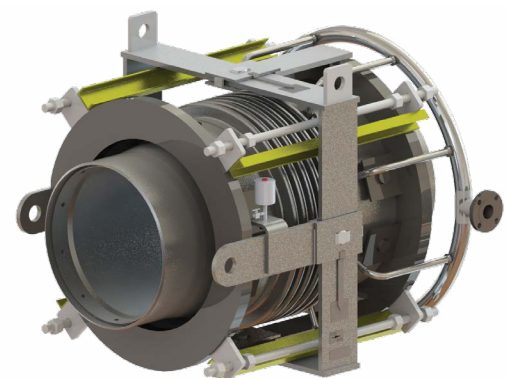

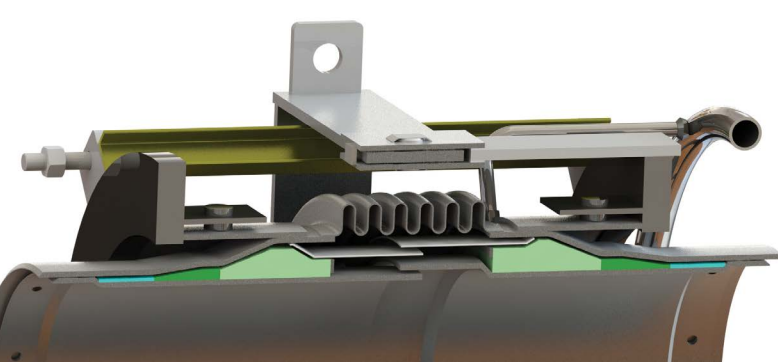

Liner Design

ADVANCED PURGING & LINER DESIGN

The Catofin process has a number of expansion joints which are purged which is typically accomplished by injecting purge gas through 8 purge ports at a pressure above the operating pressure. This floods all of the internal spaces with **purge gas and prevents formation of hard coke** which can permanently damage the internal components.

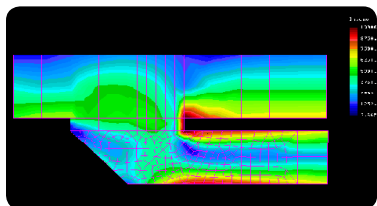

Liners must be designed for high flow velocities, mechanical loading and thermal stresses. A structurally sound liner design is utilized to accommodate vibration and buffeting from high velocity media flow. **For Catofin service a very robust liner attachment method is necessary to insure long term success.**

EXTENSIVE TESTING

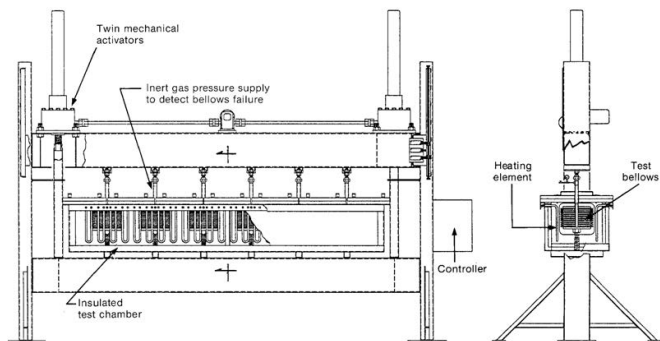

Pathway has performed extensive high temperature cycle testing which has resulted in the **development of proprietary design and manufacturing processes.** Above is a test fixture which was developed for a major Engineering firm to perform analysis on bellows operating at high temperatures.

FINITE ELEMENT ANALYSIS

Shown here is an FEA model for double expanded pipe, a special transition shape that is essential for Catofin applications. Expansion joints for Catofin service are insulated to reduce the bellows operating temperature and the temperature at critical hardware attachments. But the media temperature and line temperature is in the creep range and the temperature gradient must be absorbed in the transition.

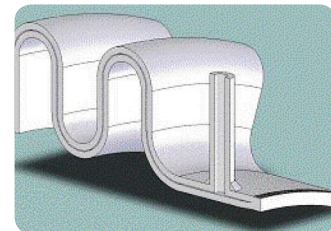
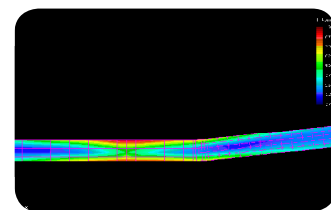

Ply Testable Cut Away
Ply-testable bellows with redundant plies are a critical feature of expansion joints in this service.

That temperature gradient results in large strains during operation and CBI Lummus has strict limits on maximum allowable strain. **The double expanded pipe profile results in a shape that achieves full compliance with CBI requirements with a minimum overall length.** FEA is used to model the double expanded pipe profile to optimize design characteristics.

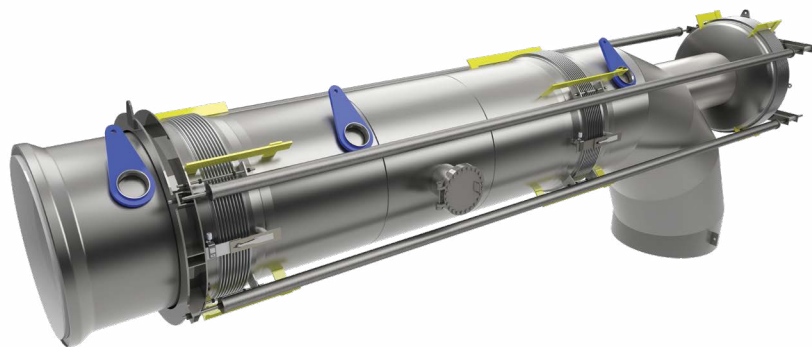

ROUND THE CLOCK SERVICE

Senior Flexonics Pathway has built a reputation on meeting customers urgent, emergency needs. We are specialists at responding to break downs, shut downs or outages. Pathway retains the expert technicians and equipment for immediate problem solving. We take on severe services and challenges, at any plant and in any part of the world.



sfpathway.com